



SIVFR Signal Isolator and Run/Fault Relay (Part No 9597) Supplemental Information for Installation and Operation Manual Part No. A40264

The SIVFR is Designed to be Used with the Following KBVF 2G Series Drives¹
(for KBVF 2G Software Revision Codes 1.47 or Higher Only)²

- KBVF-21D (Part No. 9581), KBVF-22D (Part No. 9572),
- KBVF-13 (Part No. 9957), KBVF-23 (Part No. 9958), KBVF-23D (Part No. 9959),
- KBVF-14 (Part No. 9977), KBVF-24 (Part No. 9978), KBVF-24D (Part No. 9979),
- KBVF-26D (Part No. 9496), KBVF-27 (Part No. 9591), KBVF-29 (Part No. 9593).

Notes: 1. Models KBVF-45 (Part No. 9590) and KBVF-48 (Part No. 9592) contain a built-in SIVFR. 2. The software revision code is printed on the right side of the 2.25" X 3/8" silver "WARNING: HIGH VOLTAGE!" label, which is located on the top of the KBVF heat sink. The revision code is given in the format "XX/1.47".

Kit Includes

SIVFR Signal Isolator and Run/Fault Relay PC Board, Interconnecting Ribbon Cable, Enclosure Base, Enclosure Cover, Breakaway Finger-Safe Panel, and Mounting Screws.

IMPORTANT: The following information and instructions are to be used as a supplement to the SIVF Installation and Operation Manual (Part No A40264). The SIVF and KBVF manuals must be read and understood before attempting to operate this control. For further assistance, contact our Sales Department at 954-346-4900 or Toll Free at 800-221-6570 (outside Florida).

The KBVF and SIVFR have been changed to second generation versions (2G). The General Performance Specifications have not changed. The SIVFR contains a Run/Fault Relay which can be used to turn on or off equipment or to signal a warning if the drive is put into the Stop Mode or if a fault has occurred, as described in Section 4, on pages 7 and 8.



WARNING! High voltage is present while LEDs are illuminated. Before wiring the SIVFR to the KBVF, disconnect all power to the KBVF and wait until the "PWR" and "ST" LEDs are no longer illuminated.

Notes: 1. Do not mount the SIVFR onto the KBVF until the ribbon cable is properly routed and installed. See Sections 1.1 – 1.4, on pages 2 – 4. 2. Do not install the enclosure cover until the SIVFR is mounted onto the KBVF and all wiring on the SIVFR is complete. See Sections 1.5 and 1.6, on pages 4 and 5. 3. For added protection, a break-away finger-safe panel is provided to close the exposed area of the SIVFR between Terminal Blocks TB1 and TB2. See Section 5, on page 8. 4. Jumper J5 is factory set to the "NDBM" position for operation without the optional Dynamic Brake Module installed with the KBVF. If using a Dynamic Brake Module, set Jumper J5 to the "DBM" position. See Figure 1.

Figure 1
SIVFR Layout

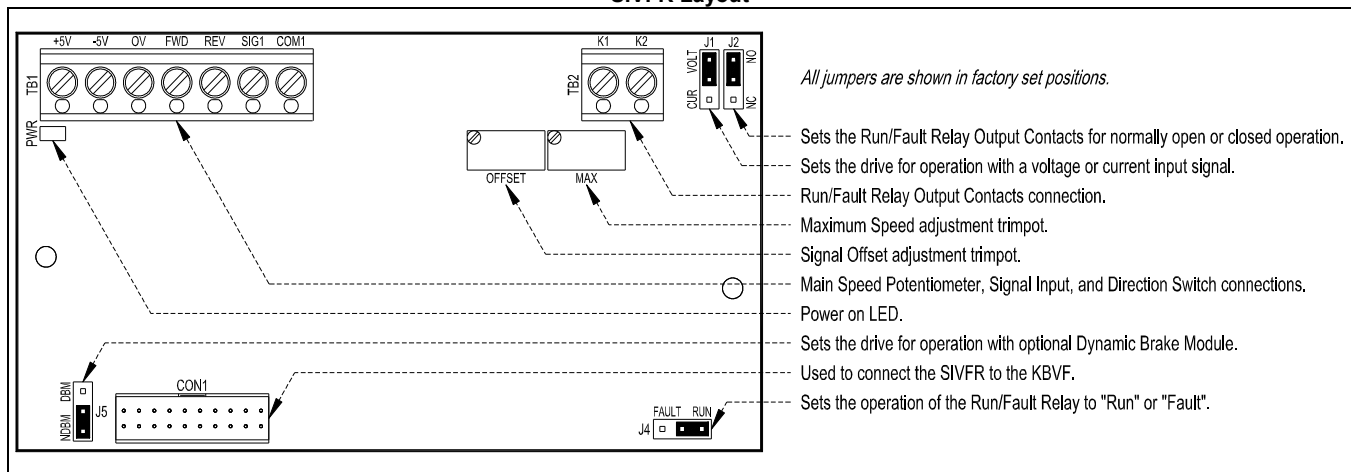



**SIVFR Signal Isolator and Run/Fault Relay (Part No 9597)
Supplemental Information for Installation and Operation Manual Part No. A40264**

1 INSTALLATION INSTRUCTIONS

WARNING! High voltage is present while LEDs are illuminated. Before wiring the SIVFR to the KBVF, disconnect all power to the KBVF and wait until the "PWR" and "ST" LEDs are no longer illuminated.

CAUTION! Before wiring and mounting the SIVFR, remove the jumper that is installed on CON2 (F-S-R) on the KBVF. Since this jumper selects motor direction, removing it will prevent the motor from rotating, should the ribbon cable ever be inadvertently disconnected while the drive is running. See Figure 2.

**Figure 2
SIVFR Installation Diagram**

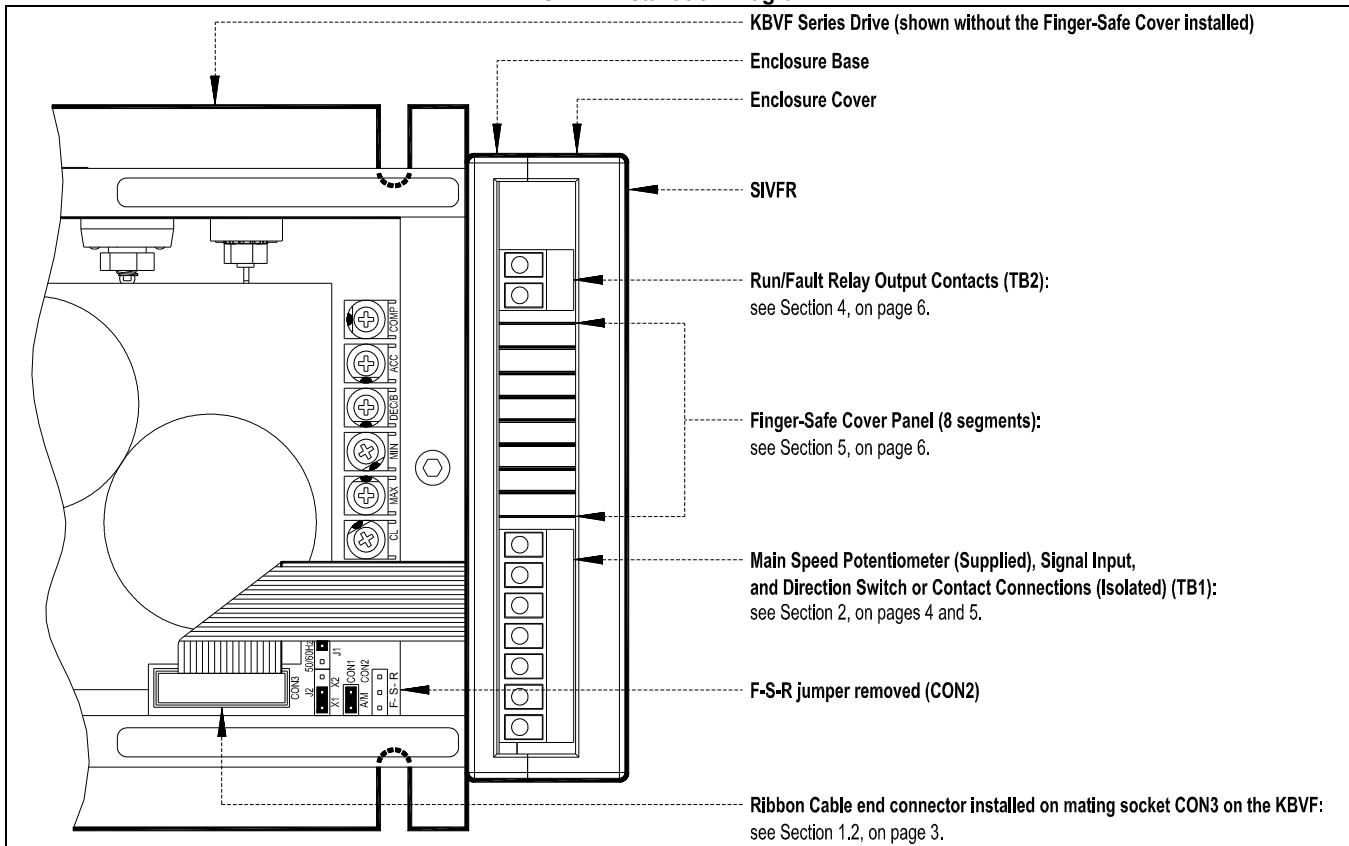

1.1 RIBBON CABLE: Notice the location of the keys and labels on each end connector of the ribbon cable, as shown in Figure 3. The end connector labeled "KBVF" installs into the mating socket on the KBVF (CON3), as described in Section 1.2, on page 3. The end connector labeled "SIVFR" installs into the mating socket on the SIVFR (CON1), as described in Section 1.4, on page 4.

**Figure 3
Ribbon Cable**

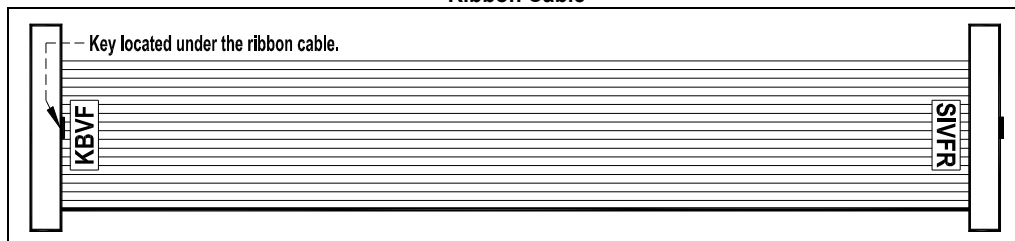



**SIVFR Signal Isolator and Run/Fault Relay (Part No 9597)
Supplemental Information for Installation and Operation Manual Part No. A40264**

- 1.2 **INSTALLING THE RIBBON CABLE ON THE KBVF:** Bend the ribbon cable at the end connector labeled "KBVF" so it is in the vertical position with the end connector facing down, as shown in Figure 4. Hold the ribbon cable to guide the end connector into the mating socket CON3 on the KBVF. Using the insulated trimpot adjustment tool (supplied with the KBVF), gently press on the end connector to fully engage it into the mating socket. Also see Figure 2, on page 2.

Figure 4
Installing the Ribbon Cable on CON3 on the KBVF

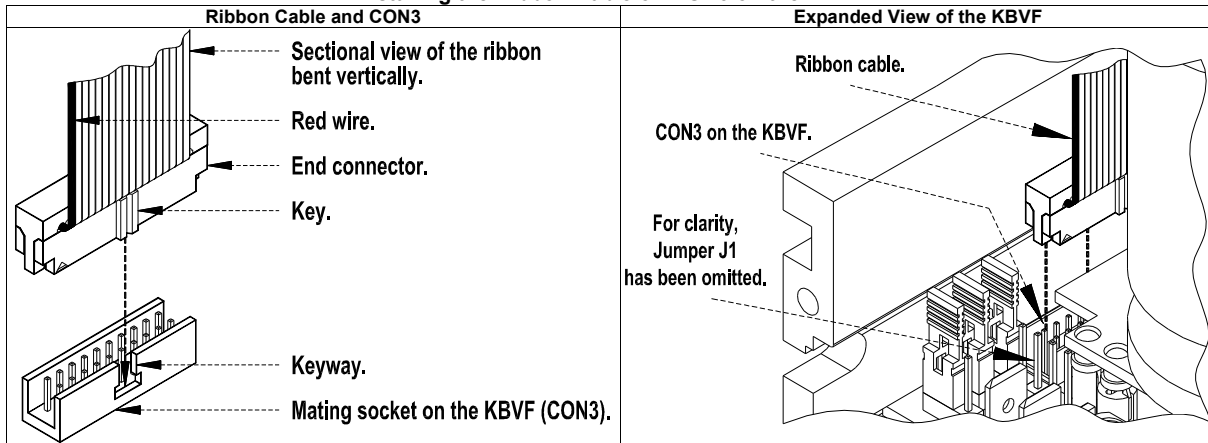

- 1.3 **REMOVING THE ENCLOSURE COVER:** Insert a small flat blade screwdriver into the slots located on both sides of the enclosure cover, as shown in Figure 5. Gently pry off the enclosure cover. The SIVFR should be properly positioned in the enclosure base, as described in Section 1.5, on page 4.

Figure 5
Removing the Enclosure Cover

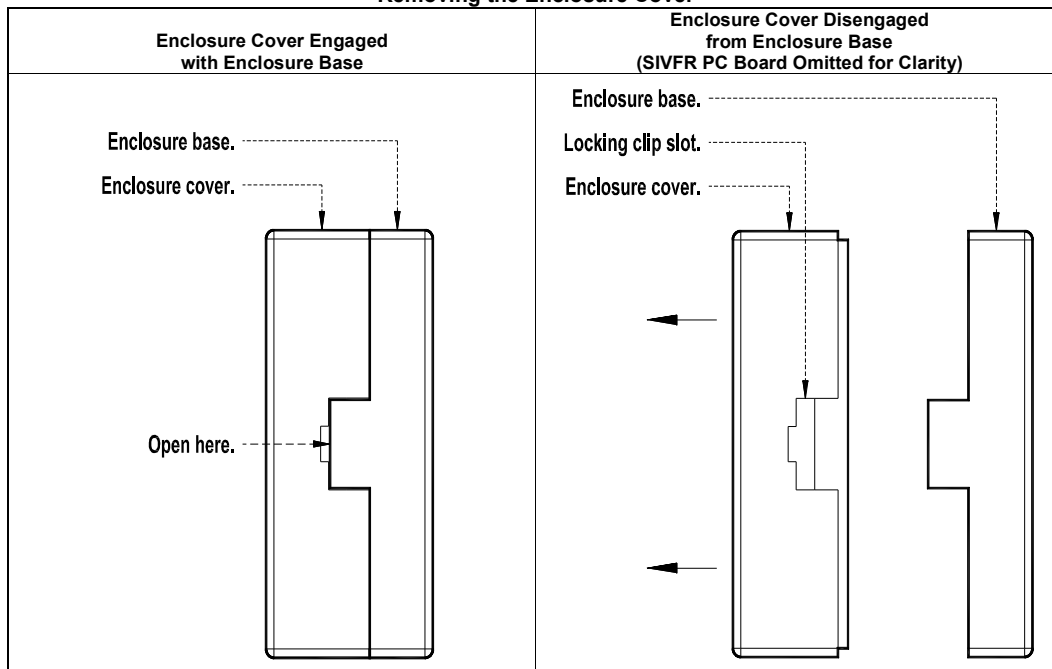

- 1.4 **INSTALLING THE RIBBON CABLE ON THE SIVFR:** Install the end connector labeled "SIVFR" into the mating socket CON1 on the SIVFR, as shown in Figure 6. The ribbon cable must be routed under and behind the enclosure base. It must lay flat (not twisted) along the back of the enclosure base.



SIVFR Signal Isolator and Run/Fault Relay (Part No 9597) Supplemental Information for Installation and Operation Manual Part No. A40264

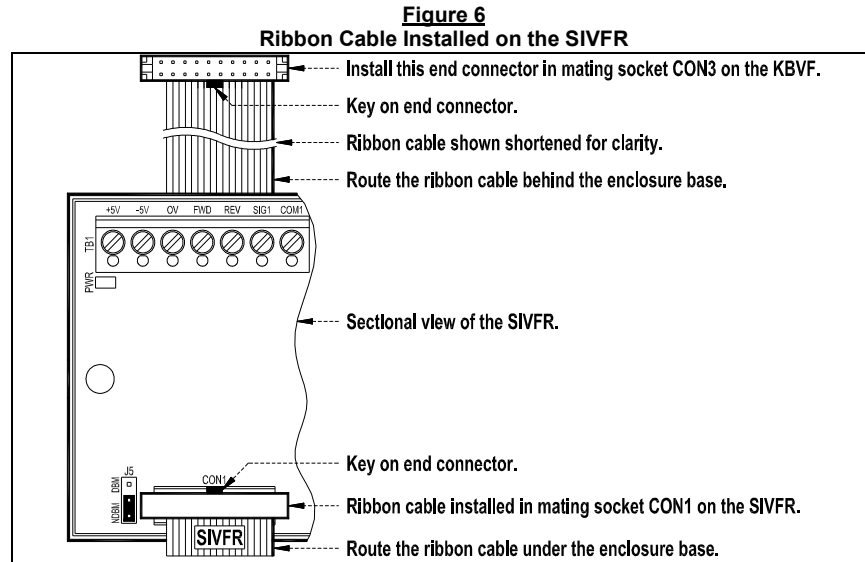

- 1.5 MOUNTING THE SIVFR:** Be sure the SIVFR PC board is properly seated and oriented in the enclosure base. The mounting holes on the SIVFR PC board must align with the mounting holes on the enclosure base. Do not install the enclosure cover until all wiring on the SIVFR is complete.

Align the SIVFR assembly mounting holes with the mounting holes located on the trimpot side of the KBVF heat sink. Insert the two 6-32 X 1/2" combination head screws (provided), through the SIVFR assembly. Use a Philips or flat blade screwdriver to tighten the screws and secure the SIVFR to the KBVF. **Do not overtighten the screws.** See Figure 7. Also see Figure 2, on page 2.

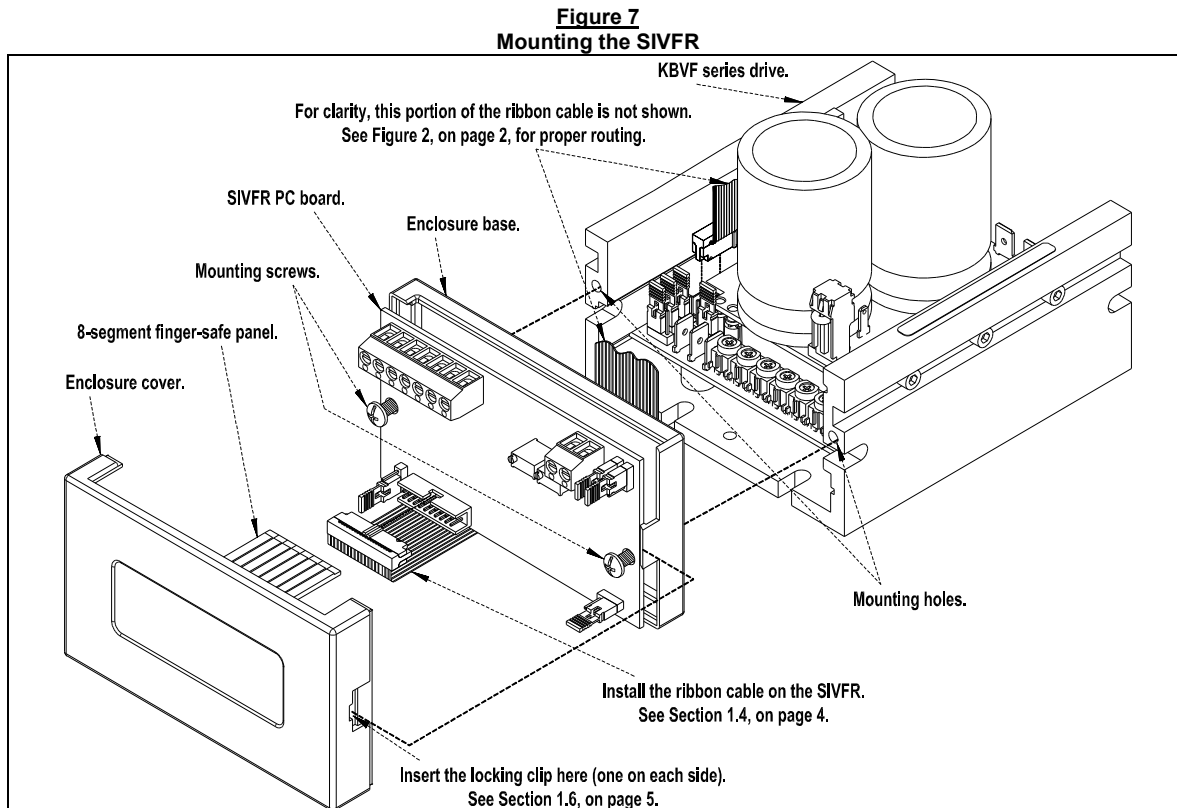



SIVFR Signal Isolator and Run/Fault Relay (Part No 9597) Supplemental Information for Installation and Operation Manual Part No. A40264

1.6 INSTALLING THE ENCLOSURE COVER: After all wiring is complete and the SIVFR is properly mounted onto the KBVF, install the enclosure cover. See Section 5, on page 8, for installing the finger-safe panel.

Orient the enclosure cover such that the label is upright (and the wider opening of the enclosure cover is at the top). Align both clips on the enclosure base with both slots on the enclosure cover. Gently push on the enclosure cover until both clips are fully engaged. See Figure 8.

Note: Be sure the "handles" of Jumpers J1, J2, J4, J5 remain inside the enclosure and they do not get crimped while installing the enclosure cover.

Figure 8
Installing the Enclosure Cover

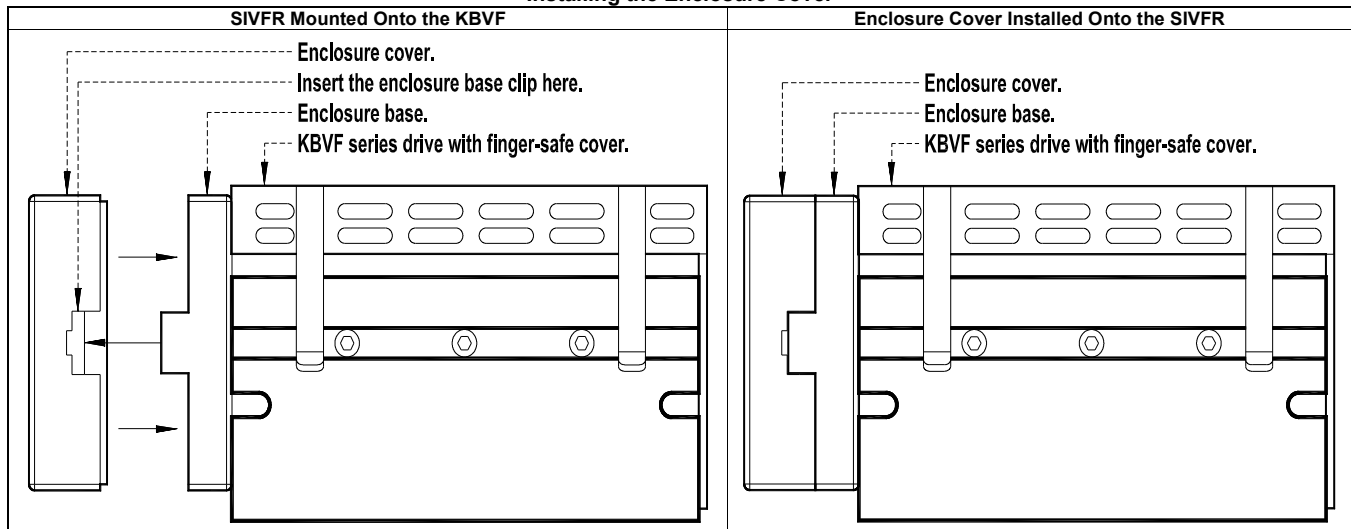

2 WIRING INSTRUCTIONS

See Table 1, for the wire size and recommended tightening torque for Terminal Blocks TB1 and TB2 on the SIVFR.

WARNING! Read Safety Warning, on page 1 of the SIVF manual, before using the drive. Disconnect main power when making connections to the drive.

Application Note: To avoid erratic operation, do not bundle the AC line and motor wires together or with wires from signal following, start/stop contacts, or any other signal wires. Also, do not bundle motor wires from multiple drives in the same conduit. Use shielded cables on all signal wiring over 12" (30 cm). The shield should be earth grounded on the drive side only. Wire the drive in accordance with the National Electrical Code requirements and other local codes that may apply.

Table 1
Terminal Block Wiring Information

Designation	Terminal Block Description	Maximum Wire Size (Cu)		Recommended Tightening Torque	
		AWG	mm ²	in-lbs	kg-cm
TB1	Main Speed Potentiometer, Signal Input, and Direction Switch	16	1.3	3.5	4
TB2	Run/Fault Relay Output Contacts				



SIVFR Signal Isolator and Run/Fault Relay (Part No 9597) Supplemental Information for Installation and Operation Manual Part No. A40264

2.1 MAIN SPEED POTENTIOMETER CONNECTION:

Wire the Main Speed Potentiometer to Terminal Block TB1 on the SIVFR. See Section 2.3, on page 6, for Forward-Stop-Reverse Switch (or Jumper) connection. If a Forward-Stop-Reverse Switch is not used, a jumper must be installed between Terminals "0V" and "FWD", of Terminal Block TB1, in order for the drive to operate.

Unidirectional Speed Operation: Wire the Main Speed Potentiometer to Terminals "+5V" (high), "SIG1" (wiper), "COM1" (low). Motor direction is selected with a Forward-Stop-Reverse Switch wired to Terminals "0V" (common of switch), "FWD", "REV". Set Jumper J1 to the "VOLT" position. See Figure 9.

Bidirectional Speed Operation: Wire the Main Speed Potentiometer to Terminals "+5V" (high), "SIG1" (wiper), "-5V" (low). Terminals "FWD", "REV", "COM1" must be hard wired together. Set Jumper J1 to the "VOLT" position. See Figure 10.

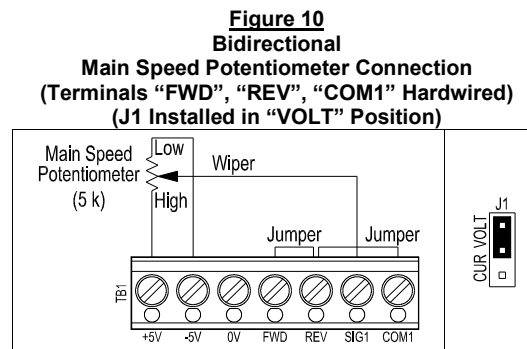
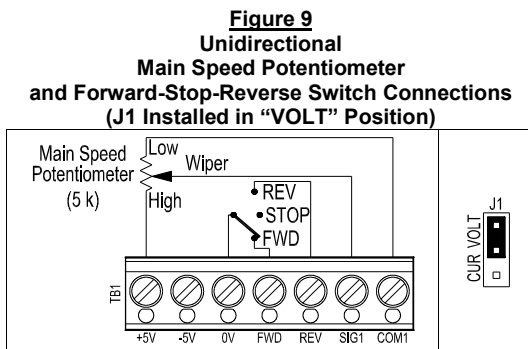

2.2 SIGNAL FOLLOWING CONNECTION: The drive output will linearly follow the analog signal input. The SIVFR is factory calibrated for 0 to ± 5 Volt DC signal input. Wire the voltage (0 to ± 2.5 thru 0 to ± 25 Volt DC) or current (4 – 20 mA DC) signal input to Terminals "SIG1" (+) and "COM1" (-) of Terminal Block TB1 on the SIVFR. A jumper must be installed between Terminals "0V" and "FWD", of Terminal Block TB1, in order for the drive to operate.

For voltage following, be sure Jumper J1 (on the SIVFR) is set to the "VOLT" position (factory setting). See Figure 11.

Application Note: In the Voltage Following Mode, the input will accept a "+" and "-" input voltage, which will run the motor in the forward and reverse direction.

For current following, set Jumper J1 (on the SIVFR) to the "CUR" position. See Figure 12. Also See Section 3.2, on page 7.

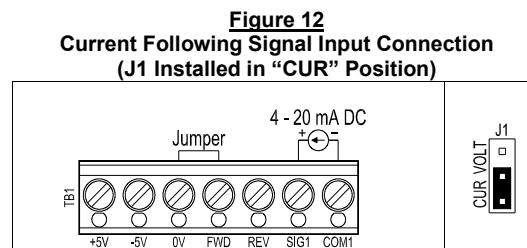
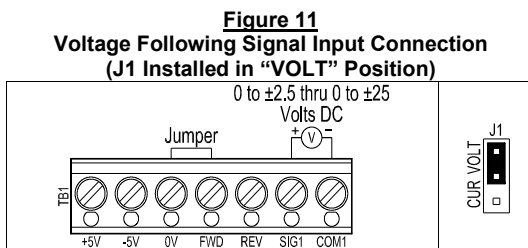

2.3 FORWARD-STOP-REVERSE SWITCH CONNECTION: Wire the Forward-Stop-Reverse Switch as shown in Figure 9. If using Form "C" Contact or Relay, wire the circuit as shown in Figure 13. If using Open Collector, wire the circuit as shown in Figure 14.

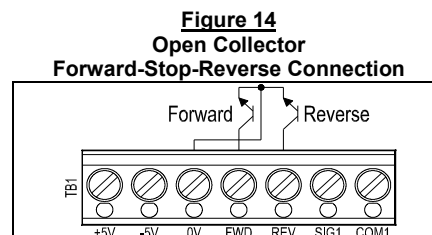
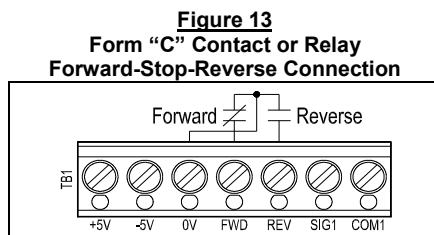



**SIVFR Signal Isolator and Run/Fault Relay (Part No 9597)
Supplemental Information for Installation and Operation Manual Part No. A40264**

3 TRIMPOT ADJUSTMENTS

The SIVFR contains multi-turn trimpots which are factory set for most applications. See Figure 1, on page 1, for the location of the trimpots.

The SIVFR is factory set for Voltage Following Operation to run the motor from zero speed to full speed with a 0 to ±5 Volt DC analog signal input. For Current Following Operation (4 – 20 mA DC), see Section 3.2.

Some applications may require readjustment of the trimpots in order to tailor the drive for a specific application. The trimpots may be readjusted as described below.

WARNING! If possible, do not adjust trimpots with the main power applied. If adjustments are made with the main power applied, an insulated adjustment tool must be used and safety glasses must be worn. High voltage exists in this drive. Fire and/or electrocution can result if caution is not exercised. Safety Warning, on page 1 of the SIVF manual, must be read and understood before proceeding.

3.1 MAXIMUM SPEED (MAX): The MAX Trimpot is factory set to run the motor at full speed with a ±5 Volt DC analog signal input. For a higher analog signal input (±25 Volt DC max.) rotate the MAX Trimpot counterclockwise. For a lower analog signal input (±2.5 Volt DC min.) rotate the MAX Trimpot clockwise. See Figure 15.

Note: The MAX Trimpot on the KBVF has been factory set to an Upper Frequency Limit of 60 Hz (50 Hz, for 50 Hz motors). If the application requires a slightly higher maximum frequency (up to 66 Hz), rotate the MAX Trimpot on the KBVF to full clockwise position.

3.2 SIGNAL OFFSET (OFFSET): The OFFSET Trimpot is used to recalibrate the drive for Current Following Operation. The SIVFR will run the motor from zero speed to full speed with a 4 – 20 mA DC analog signal input. For a higher minimum speed setting, rotate the OFFSET trimpot clockwise. For a lower minimum speed setting rotate the OFFSET Trimpot counterclockwise. See Figure 16.

Note: The MIN Trimpot on the KBVF is not functional when the SIVFR is installed.

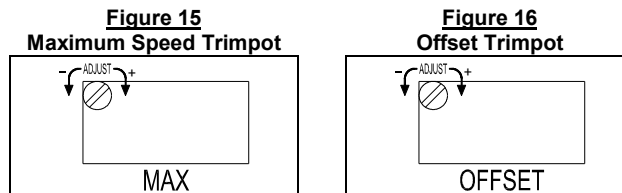

4 RUN/FAULT RELAY

The Run/Fault Relay Output Contacts are located at TB2 of the SIVFR and can be used to turn on or off equipment or to signal a warning if the drive is put into the Stop Mode or if a fault has occurred. See Figure 17.

See Table 2 for the drive operating condition and Run/Fault Relay Contact status.

For normally open contact, set Jumper J2 on the SIVFR to the "NO" position. For normally closed contact, set Jumper J2 on the SIVFR to the "NC" position. See Figure 18.

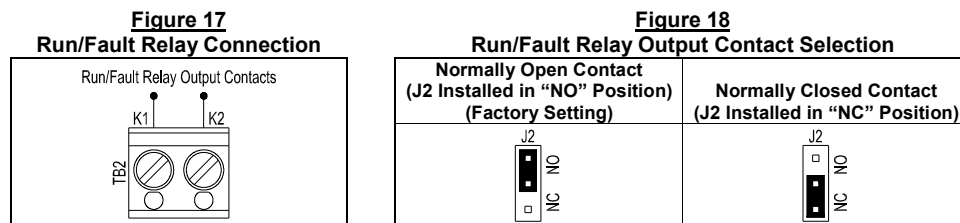



**SIVFR Signal Isolator and Run/Fault Relay (Part No 9597)
Supplemental Information for Installation and Operation Manual Part No. A40264**

Table 2
Drive Operating Condition and Run/Fault Relay Contact Status

Drive Operating Condition	Relay Contact Status (Terminals K1 and K2 of TB2)			
	Run Relay Operation (J4 Installed in "RUN" Position) (Factory Setting)		Fault Relay Operation (J4 Installed in "FAULT" Position)	
	J2 Installed in "NO" Position (Factory Setting)	J2 Installed in "NC" Position	J2 Installed in "NO" Position (Factory Setting)	J2 Installed in "NC" Position
Power Off (Main Power Disconnected)	Open	Closed	Open	Closed
Run Mode* (Normal Drive Operation)	Closed	Open	Closed	Open
Stop Mode* (Selected by Operator)	Open	Closed	Closed	Open
Fault** (Drive Tripped)	Open	Closed	Open	Closed

*Run Mode or Stop Mode is selected using the Forward-Stop-Reverse Switch. **Fault: Overload, I²t, Short Circuit, Undervoltage, and Overvoltage.

5 OPTIONAL FINGER-SAFE PANEL

The SIVFR is supplied with a finger-safe panel which may be used with the enclosure cover to close the unused exposed area of the SIVFR between Terminal Blocks TB1 and TB2. The finger-safe panel is a 24-segment panel. Only an 8-segment piece is needed for the SIVFR. The finger-safe panel may be separated into three equal size pieces. See Figure 19.

WARNING! Use caution and wear eye protection when snapping off or cutting off sections of the finger-safe panel.

5.1 Segmenting the Finger-Safe Panel: By bending the finger-safe panel back and forth at the breakaway points, snap off an 8-segment piece (1¼" in length). See Figure 20.

Figure 19
24-Segment Finger-Safe Panel

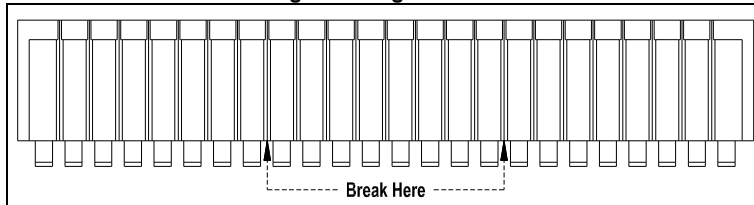
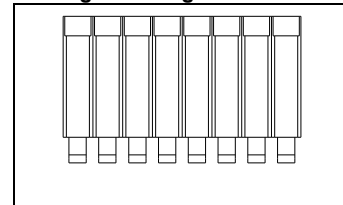

Figure 20
8-Segment Finger-Safe Panel



5.2 Installing the 8-Segment Finger-Safe Panel: Notice the locking clip on the side view of the finger-safe panel, as shown in Figure 21. Install the 8-segment panel into the enclosure cover with the locking clip facing toward the center of the enclosure cover, as shown in Figure 22. Also see Figure 2, on page 2.

Figure 21
Side View of the Finger-Safe Panel

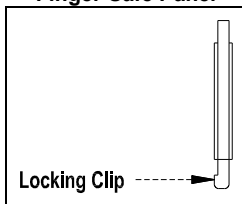
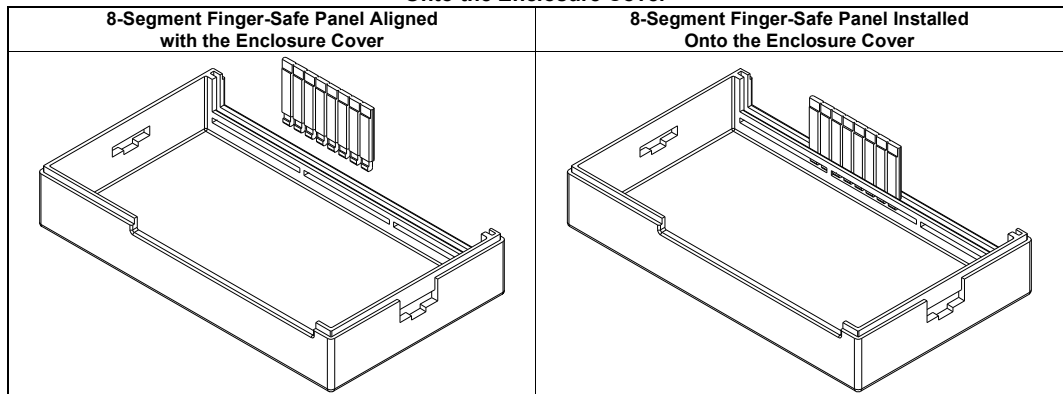

Figure 22
Installing the 8-Segment Finger-Safe Panel Onto the Enclosure Cover



INSTALLATION AND OPERATING INSTRUCTIONS

MODEL SIVF

KB Part No. 9474 – Signal Isolator for KBVF Controls

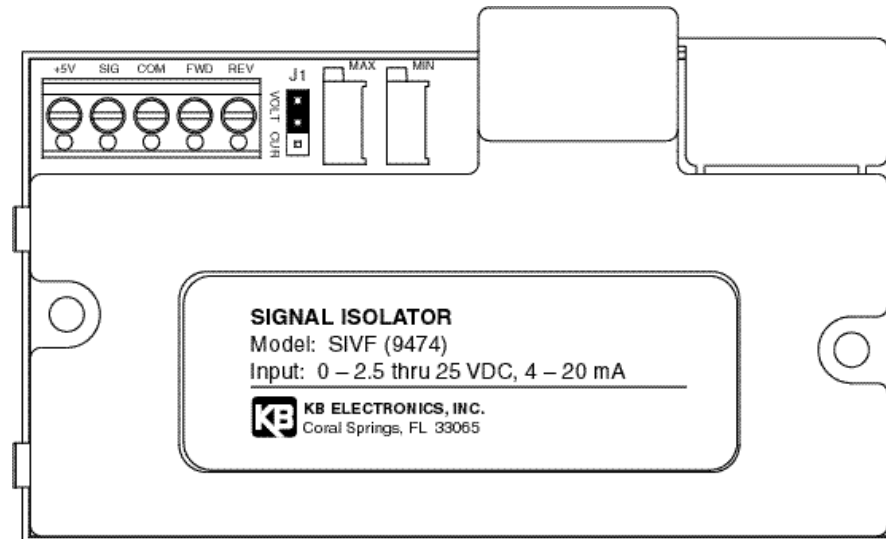

See Page 1



Pending



See Safety Warning on Page 1

The information contained in this manual is intended to be accurate. However, the manufacturer retains the right to make changes in design which may not be included herein.

PENTA  POWER

A COMPLETE LINE OF MOTOR DRIVES

© 1999 KB Electronics, Inc.

TABLE OF CONTENTS

<u>SECTION</u>	<u>Page</u>
i. Safety Warning	1
I. Introduction	3
II. Installation Instructions	4
III. Connections to the SIVF	9
IV. Calibration Procedure	13
V. Limited Warranty	18
Addendum I	15

TABLE

1. General Performance Specifications	4
2. Terminal Block Wiring Information	9

FIGURE

1. Control Layout	2
2. SIVF Connection Diagram	5
3. SIVF Mounting Diagram	6
4A. SIVF Mechanical Specifications (Mounted to 1/2HP KBVF)	7
4B. SIVF Mechanical Specification (Mounted to 1HP KBVF)	8
5. Voltage Following Connection	10
6. Current Following Connection	11
7. Potentiometer Connection	11
8. Unidirectional Operation	12
9. Switch Connection	12
10. Open Collector Connection	13
11. Finger-Safe Cover	16

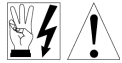

i. SAFETY WARNING! PLEASE READ CAREFULLY

This product should be installed and serviced by a qualified technician, electrician or electrical maintenance person familiar with its operation and the hazards involved. Proper installation, which includes wiring, mounting in proper enclosure, fusing or other overcurrent protection and grounding, can reduce the chance of electric shocks, fires or explosion in this product or products used with this product, such as electric motors, switches, coils, solenoids and/or relays. Eye protection must be worn and insulated adjustment tools must be used when working with control under power. This product is constructed of materials (plastics, metals, carbon, silicon, etc.) which may be a potential hazard. Proper shielding, grounding and filtering of this product can reduce the emission of radio frequency interference (RFI) which may adversely affect sensitive electronic equipment. If information is required on this product, contact our factory. It is the responsibility of the equipment manufacturer and individual installer to supply this safety warning to the ultimate user of this product. (SW effective 11/92)

This control contains electronic start/stop circuits that can be used to start and stop the control. However, these circuits are never to be used as safety disconnects since they are not fail-safe. Use only the AC line for this purpose.

Be sure to follow all instructions carefully. Fire and/or electrocution can result due to improper use of this product.



This product complies with all CE directives pertinent at the time of manufacture. Contact factory for detailed installation instructions and Declaration of Conformity.

FIGURE 1 – CONTROL LAYOUT

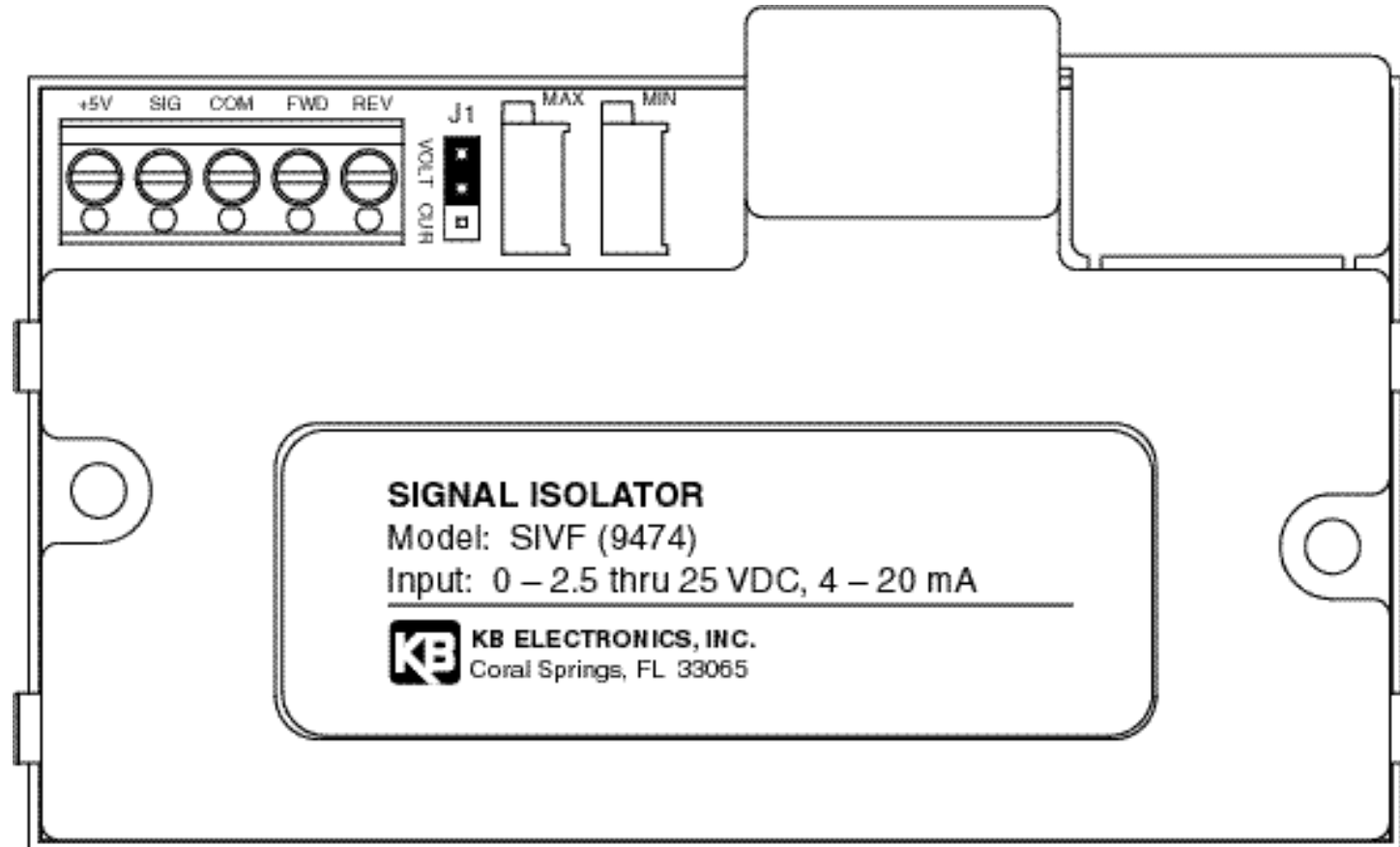

I. INTRODUCTION

Thank you for purchasing the SIVF Signal Isolator (P/N 9474). KB Electronics, Inc. is committed to providing total customer satisfaction by producing high quality products that have been manufactured to the highest standards and techniques in the industry. The SIVF is engineered with state-of-the-art surface mount technology (SMT) incorporating advanced circuitry in a relatively small and user friendly package, making it convenient to operate and easy to install.

The SIVF is used to isolate, amplify, and condition DC voltage and current signals from any source (power supplies, motors, tachometer generators, transducers, and potentiometers). The isolated output voltage of the SIVF provides input signals to all models of the KBVF Adjustable Frequency Drive (P/N 9957, 9958, 9959, 9977, 9978, and 9979). Signal input and motor direction control is performed by making connections to the on-board barrier terminal. All inputs (+5V, SIG, COM, FWD & REV) to the SIVF are isolated from the AC line and motor connections.

The SIVF is factory calibrated to accept signal input voltage (0 – 5V DC), current (4 – 20mA DC), or a potentiometer (5K) via a jumper selection. MIN and MAX trimpots are provided in order to readjust the SIVF. This allows the use of 0 – 2.5 thru 25V DC input voltage signals for customizing specific applications.

TABLE 1 – GENERAL PERFORMANCE SPECIFICATIONS

Voltage Following Operation Input Range (V DC)	0 – 2.5 thru 25
Current Following Operation Input Range (mA DC)	4 – 20
Potentiometer Operation (K)	5
Output Voltage at P2 (V DC)	0 – 5
MIN Trimpot Range (with 0 Volts Input) (% Full Speed)	0 – 40
MAX Trimpot Range (with 5 Volts Input) (% Full Speed)	70 – 110
FWD and REV Input Switch Types	Dry Contact or Open Collector
Linearity (%)	0.5
Thermal Drift (mV/ °C)	1.0
Electromagnetic Compatibility (V/m at 80-1000M Hz)	3

II. INSTALLATION INSTRUCTIONS

Note: If the KBVF contains a finger safe cover, (KB P/N 9473) see Addendum I on page 15.

See figure 2, SIVF Connection Diagram, on page 5.



WARNING: HIGH VOLTAGE IS PRESENT WHILE LEDs ARE ILLUMINATED.

Before wiring the SIVF to the KBVF, disconnect all power to the KBVF and wait until “PWR” and “ST” LEDs are no longer illuminated.

A. Wiring the SIVF to the KBVF – (Note: Do not install the SIVF to the KBVF until wiring is completed.)

1. Remove the F-S-R jumper which is installed on CONN2 of the KBVF. Attach the 3-pin connector (with white, black, and red wires) from the SIVF to the KBVF connector marked “CONN2”.
2. Attach the red wire from the SIVF to the KBVF terminal marked “J3”.
3. Attach the orange wire from the SIVF to the KBVF terminal marked “P2”.

FIGURE 2 – SIVF CONNECTION DIAGRAM

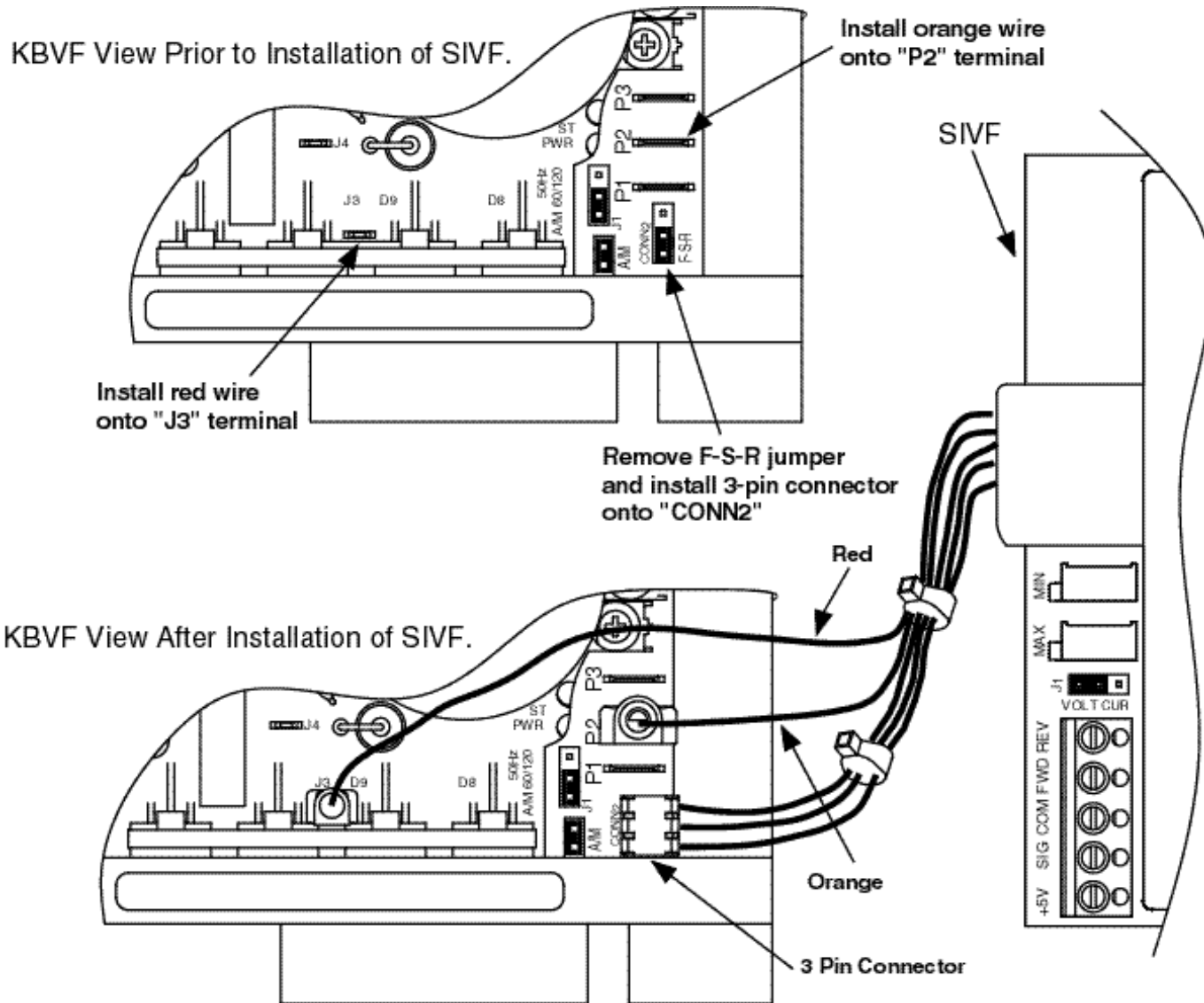

FIGURE 3 – SIVF MOUNTING DIAGRAM

(Shown Mounted to Model KBVF-24D)

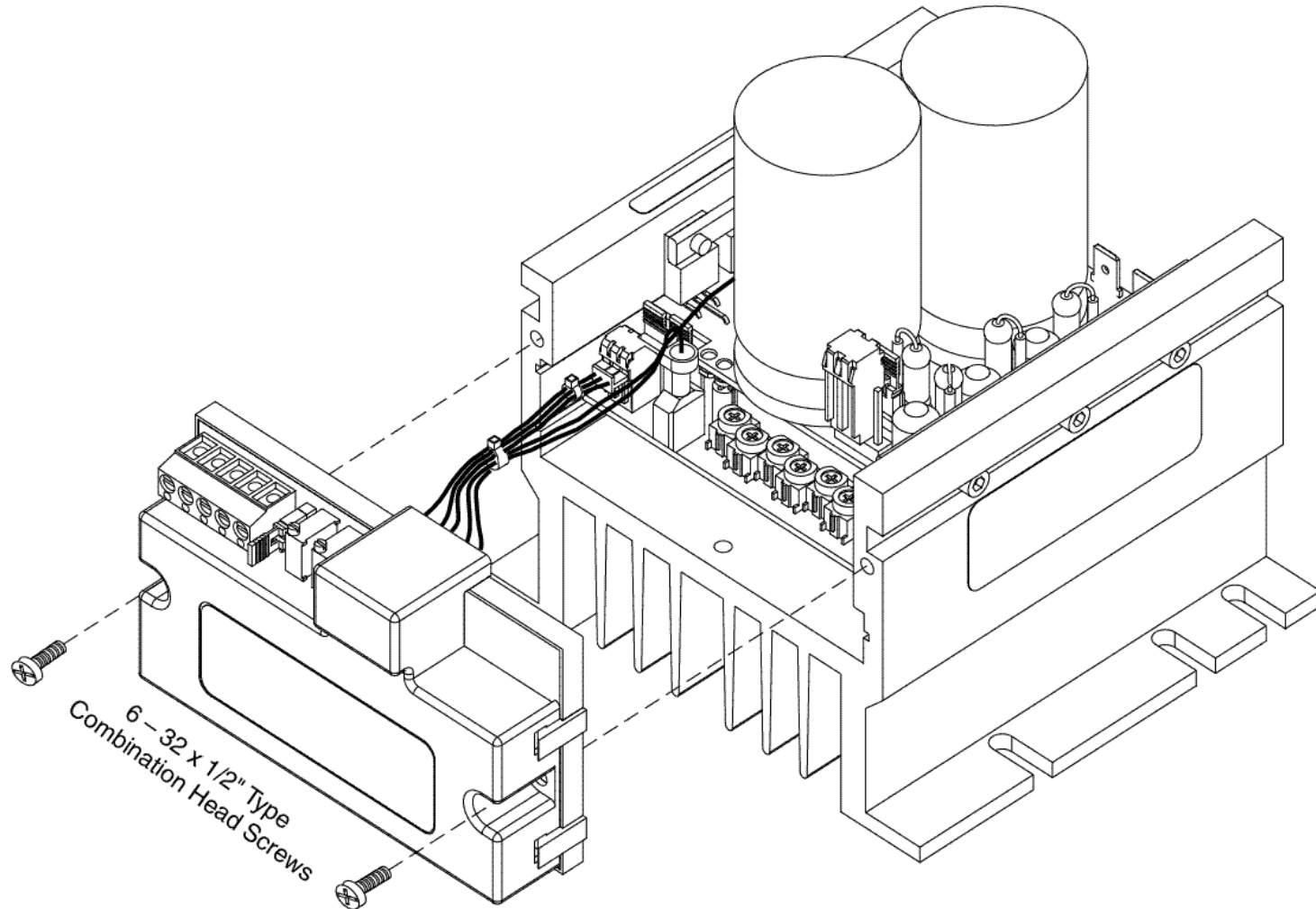

FIGURE 4A – SIVF MECHANICAL SPECIFICATIONS (Inches / mm)

(Shown Mounted to 1/2HP KBVF – With Optional Finger-Safe Cover)

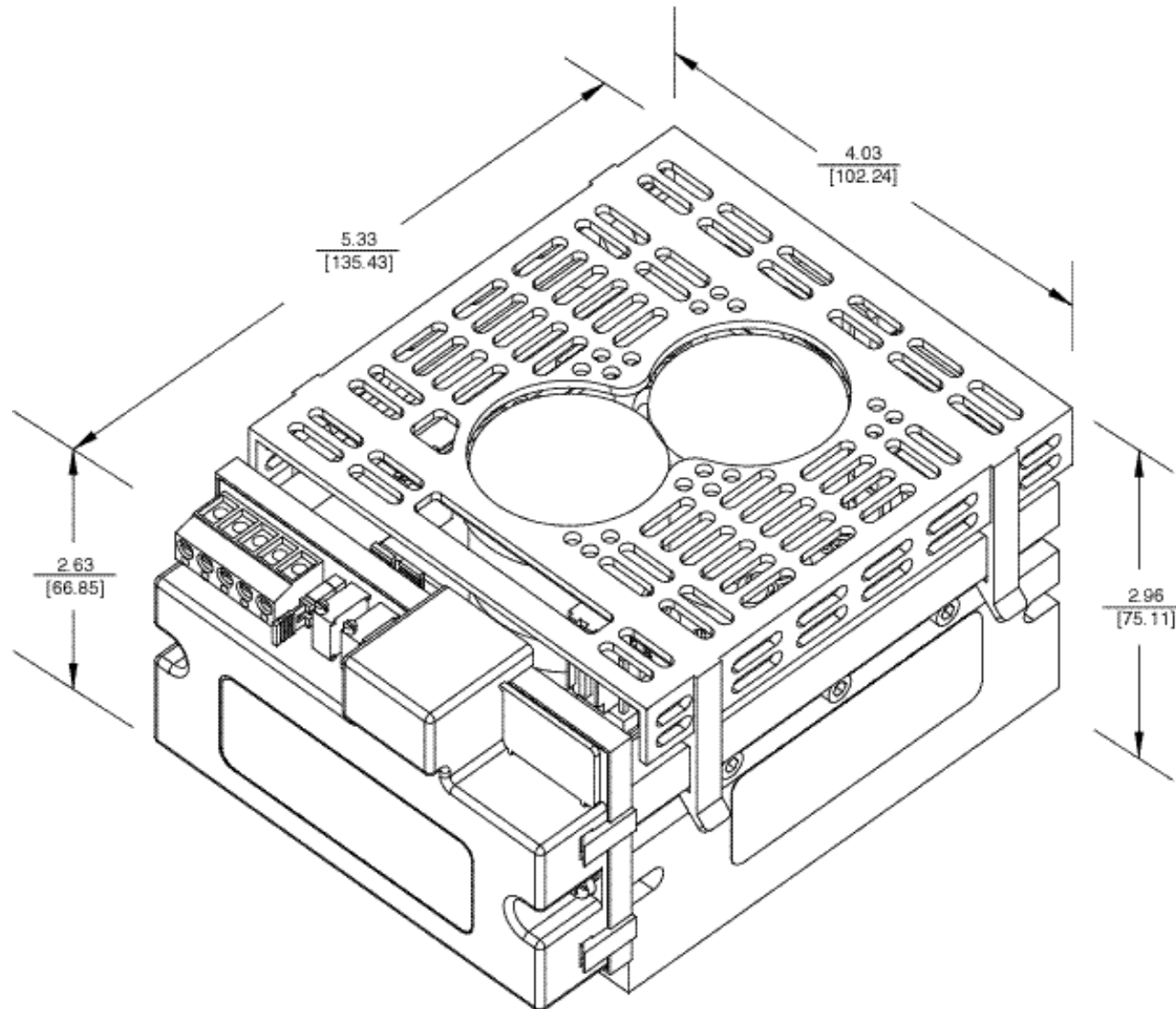
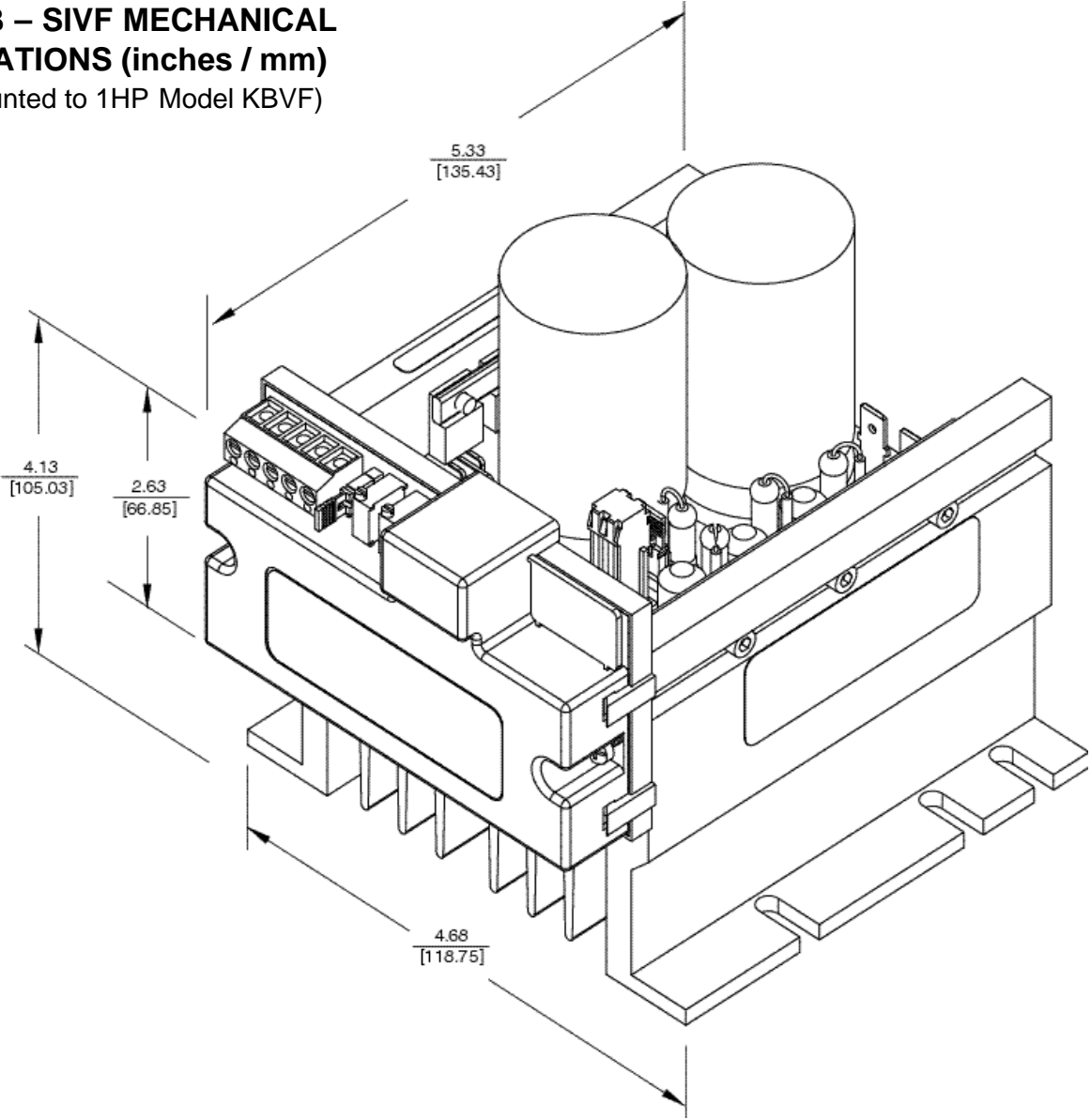

FIGURE 4B – SIVF MECHANICAL SPECIFICATIONS (inches / mm)
(Shown Mounted to 1HP Model KBVF)



B. MOUNTING THE SIVF ONTO THE KBVF

See figure 3, SIVF Mounting Diagram.

See figures 4A and 4B, SIVF Mechanical Specifications, on pages 7 and 8.

The SIVF is installed onto the KBVF using (2) two 6-32 X 1/2" screws provided.

Note: The screws are a combination head type which allow the use of a readily available #1 or #2 phillips or slotted head screwdriver.

Note: Before installing the SIVF be sure the wiring to the KBVF has been completed. See section II, Installation Instructions, on page 3

1. Align the SIVF mounting holes with the tapped holes on the KBVF heat sink and insert the screws through the SIVF mounting holes.
2. Using a screwdriver, fasten both screws until the SIVF is secured to the KBVF (8 in-lbs max). Do not over tighten screws or damage may result to SIVF cover.

TABLE 2 – TERMINAL BLOCK WIRING INFORMATION

Connection Designation	Supply Wire Gauge (AWG – Cu)		Maximum Tightening Torque (in-lbs)
	Minimum	Maximum	
Logic Connections	24	14	3.5

III. CONNECTIONS TO THE SIVF



Safety Warning! Do not use FWD-STOP-REV contacts as a safety disconnect since they are not fail-safe. Use only the AC line for this purpose.

Note: A connection must be made between FWD and COM or REV and COM in order for control to operate. Jumper shown installed in FWD direction.

See Table 2, Terminal Block Wiring Information, on page 9.

Note: The MIN and MAX trimpots on the KBVF are non-operational after the SIVF is installed.

A. Signal Following

In this mode, a signal source is used to vary motor speed.

- i. **Voltage Following** – Uses a voltage source to vary motor speed.

Set J1 to “VOLT” position and connect the voltage source to TB1 terminals SIG (+) figure 5, Voltage Following Connection. Be :
 tive (+) signal is connected to “SIG” terminal
 negative (-) is connected to the “COM” termi
 nal.

When a 0V DC signal is applied, the motor will operate at the minimum set speed (set by the MIN trimpot on the SIVF). When a 5V DC signal is applied, the motor will operate at the maximum set speed (set by the MAX trimpot on the SIVF).

Figure 5 – Voltage Following Connection (Jumper J1 in “VOLT” Position)

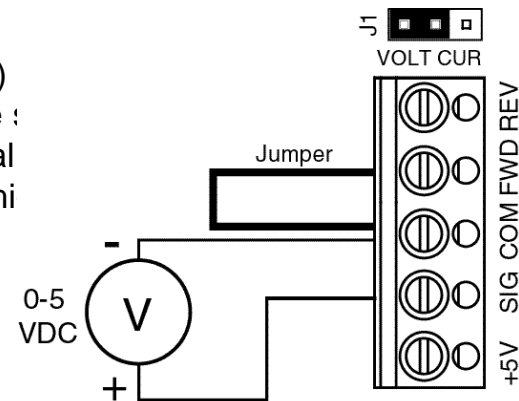

- ii. **Current Following** – Uses a current source to vary motor speed.

Set J1 to “CUR” position and connect the current source to TB1 terminals SIG (+) and COM (-). See figure 7, Current Following Connection, on page 11.

Be sure the positive (+) signal is connected to “SIG” terminal and the negative (-) is connected to the “COM” terminal.

When a 4mA DC signal is applied, the motor will operate at the minimum set speed (set by the MIN trimpot on the SIVF). When a 20mA DC signal is applied, the motor will operate at the maximum set speed (set by the MAX trimpot on the SIVF)

B. Potentiometer Operation – Uses a potentiometer to vary motor speed.

Set J1 to “VOLT” position and connect the 5K potentiometer to TB1 terminals marked “SIG” (wiper of potentiometer), “+5” (high side of potentiometer), and “COM” (low side of potentiometer). See figure 7 Potentiometer Connection. When the potentiometer is set to 0% (counter-clockwise position), the motor will operate at the minimum set speed (set by the MIN trimpot on the SIVF). When the potentiometer is set to 100% (full clockwise position) the motor will operate at full speed (set by the MAX trimpot on the SIVF)

C. Unidirectional Operation

To operate the control in forward, install a jumper between “FWD” and “COM” terminals of the SIVF

To operate the control in reverse, install a jumper between “REV” and “COM” terminals

Figure 6 – Current Following Connection (Jumper J1 in “CUR” Position)

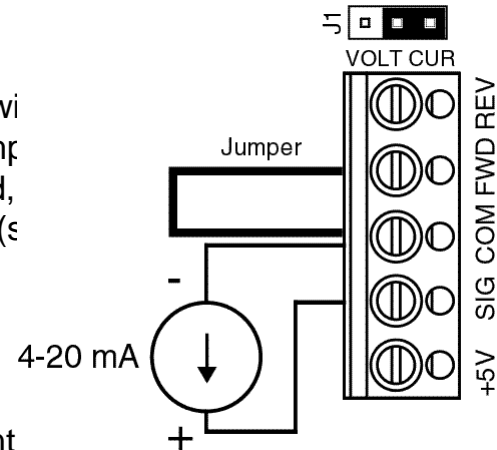
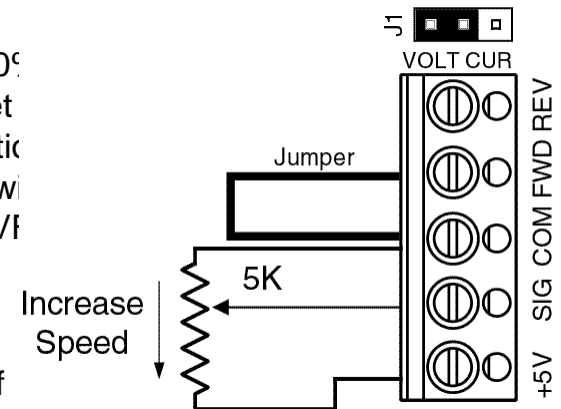

Figure 7 – Potentiometer Connection (Jumper J1 in “VOLT” Position)



nals of the SIVF. See figure 8, Unidirectional Operation.

Note: A SPDT switch or contact can be used as an enable to turn control on and off electronically.

Figure 8 – Unidirectional Operation

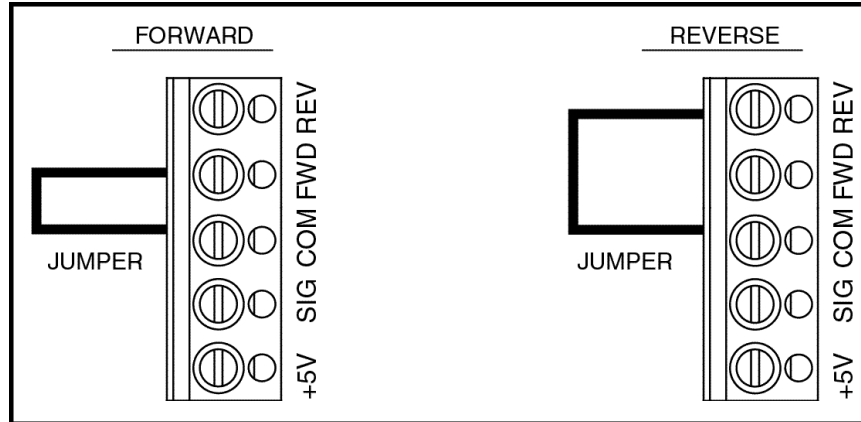

! Safety Warning! Do not use FWD-STOP-REV contacts as a safety disconnect since they are not fail-safe. Use only the AC line for this purpose.

D. Bidirectional Operation

- i. **Switch Connection –**
Connect the normally open single pole double throw (SPDT) maintained switch with center off position as shown in figure 9. The center, or common terminal of the switch connects to the “COM” terminal of the SIVF and the normally open terminals of the switch connect to the “FWD” and “REV” terminals of the SIVF.

Figure 9 – Switch Connection (Forward-Stop-Reverse)

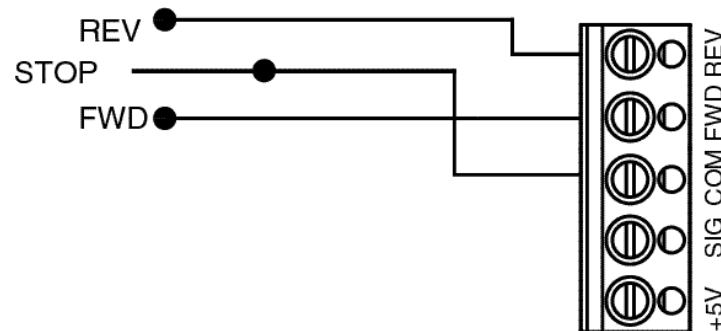

Making the connection between “COM” and “FWD” terminals will operate the motor in the forward direction. Making the connection between the “COM” and “REV” terminals will operate the motor in the reverse direction. If no connections are made to either FWD or REV terminals, the motor will be in the STOP state. See figure 9, Switch Connections, on page 12. If the motor runs in the opposite intended direction, interchange FWD and REV connections.

Figure 10 – Open Collector Connection (Forward-Stop-Reverse)

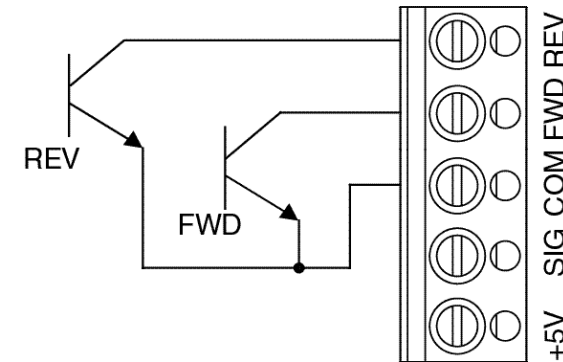

 **Warning:** Be sure to disconnect AC power, and wait until “PWR” and “ST” LEDs are no longer illuminated. HIGH VOLTAGE IS PRESENT WHILE LEDs ARE ILLUMINATED.

- ii. **Open Collector Transistor Connections** – Connect the open collector transistor circuit as shown in figure 10. Both emitters of the transistor circuit connect to the “COM” terminal of the SIVF and the collectors of the transistor circuit connect to the “FWD” and “REV” terminals of the SIVF.

IV. CALIBRATION PROCEDURE (See Safety Warning on Page 1)

The SIVF is factory calibrated, but readjustments to the MIN and MAX trimpots can be made to customize for a particular signal input requirement.

Note: Adjustments to the MAX trimpot will affect the MIN trimpot setting. It may be necessary to repeat steps 1 through 5 to achieve accurate calibration settings. For best results, adjust MAX trimpot before adjusting MIN trimpot.

- A. Calibrating the SIVF for Voltage Following (Jumper J1 in “VOLT” position):**
1. Select FWD or REV direction.
 2. Apply the maximum voltage input signal.
 3. Monitor KBVF output and adjust the MAX trimpot on SIVF for the desired maximum setting.
 4. Apply the minimum voltage input signal.
 5. Monitor KBVF output and adjust the MIN trimpot on SIVF for the desired setting.
- B. Calibrating the SIVF for Current Following (Jumper J1 in “CUR” position):**
1. Select FWD or REV direction.
 2. Apply the maximum current input signal.
 3. Monitor KBVF output and adjust the MAX trimpot on SIVF for the desired maximum setting.
 4. Apply the minimum current input signal.
 5. Monitor KBVF output and adjust the MIN trimpot on SIVF for the desired minimum setting.
- C. Calibrating the SIVF for Potentiometer Operation (J1 in “VOLT” position):**
1. Select FWD or REV direction.
 2. Set potentiometer to 100% (fully clockwise).
 3. Monitor KBVF output and adjust the MAX trimpot on SIVF for the desired KBVF output.
 4. Set potentiometer to 0% (fully counterclockwise).
 5. Monitor KBVF output and adjust the MIN trimpot on SIVF for the desired minimum setting.

– ADDENDUM I –

Instructions to Modify the Optional Finger-Safe Cover (KB P/N 9473).

If using the optional finger-safe cover on the KBVF, it needs to be modified to install the KBVF.



WARNING: HIGH VOLTAGE IS PRESENT WHILE LEDs ARE ILLUMINATED.

Before removing the finger safe cover, or wiring the KBVF, disconnect all power to the KBVF and wait until “PWR” and “ST” LEDs are no longer illuminated.

Note: If a finger-safe cover is already installed on the KBVF, remove it by lifting up on the four (4) retaining clips (see figure 11, Finger-Safe Cover, on page 16).

Instructions to modify the finger-safe cover:

1. Cut off the end section with three (3) tabs of the finger-safe cover at nine (9) places, as shown in figure 11, Finger-Safe Cover.
2. Before installing the finger-safe cover onto the KBVF, connect orange wire, red wire and 3-pin connector to KBVF.
3. Install SIVF onto KBVF before installing the finger-safe cover (see section II, on page 4).
4. Install the finger safe cover onto the KBVF using the four (4) retaining clips.

FIGURE 11 – FINGER-SAFE COVER

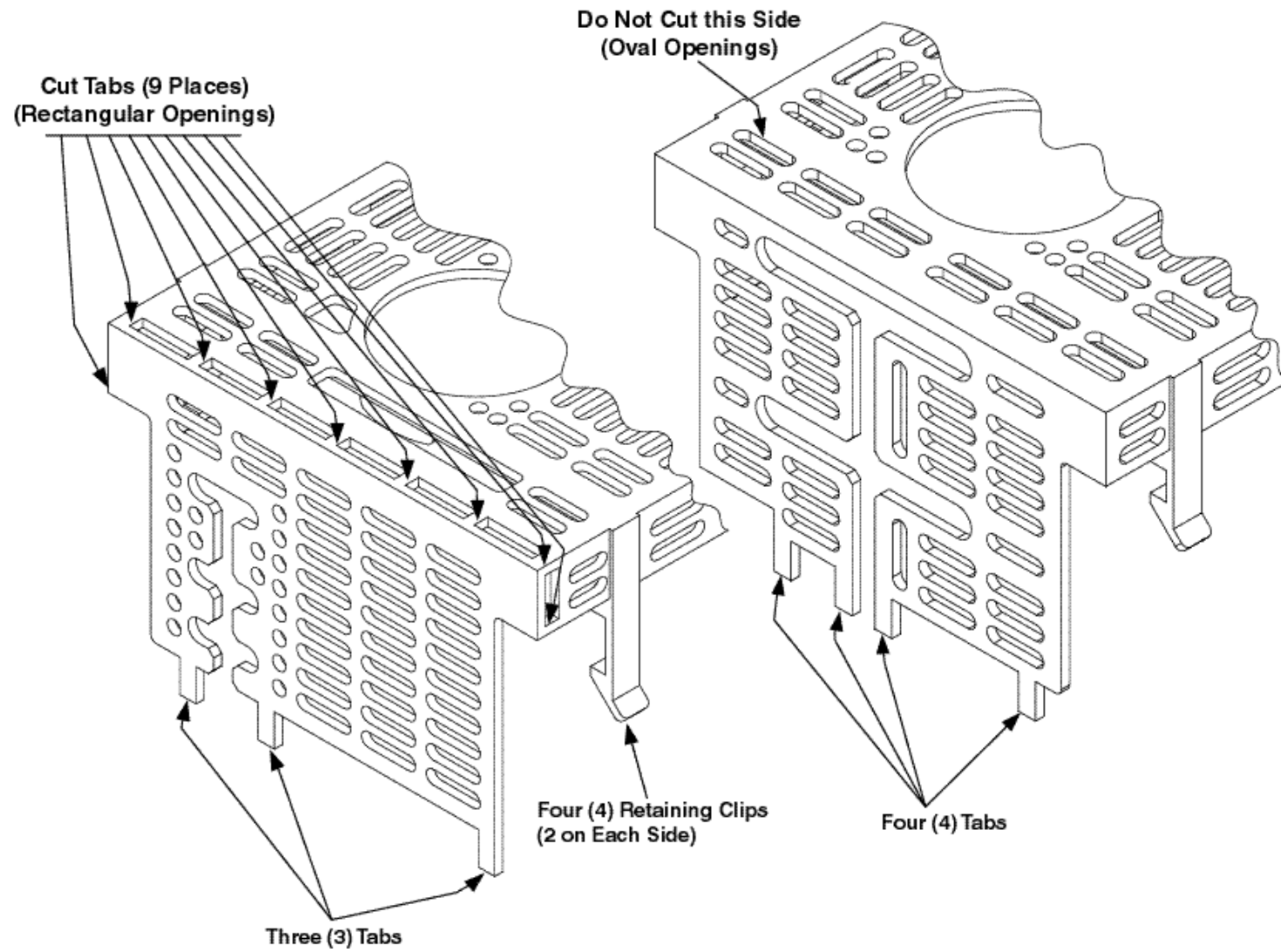

– NOTES –

V. LIMITED WARRANTY

For a period of 18 months from date of original purchase, KB will repair or replace without charge devices which our examination proves to be defective in material or workmanship. This warranty is valid if the unit has not been tampered with by unauthorized persons, misused, abused, or improperly installed and has been used in accordance with the instructions and/or ratings supplied. The foregoing is in lieu of any other warranty or guarantee, expressed or implied, and we are not responsible for any expense, including installation and removal, inconvenience, or consequential damage, including injury to any person, caused by items of our manufacture or sale. Some states do not allow certain exclusions or limitations found in this warranty so that they may not apply to you. In any event, KB's total liability, under all circumstances, shall not exceed the full purchase price of this unit. (rev 4/88)



KB ELECTRONICS, INC.

12095 NW 39th Street, Coral Springs, FL 33065-2516 • (954) 346-4900 • Fax (954) 346-3377
Outside Florida Call **TOLL FREE** (800) 221-6570 • E-mail – info@kbelectronics.com
www.kbelectronics.com